

## Multistage Implementation of Narrowband LPF by Decimator in Multirate DSP Application.

Prashant Kumar<sup>1</sup>, Rajesh Mehra<sup>2</sup>

<sup>1</sup>(Department of Electronics and Communication Engineering, NITTTR Chandigarh, India)

<sup>2</sup>(Department of Electronics and Communication Engineering, NITTTR Chandigarh, India)

**Abstract:** Decimator is an important sampling device used for multi-rate signal processing in wireless communication systems. Multirate systems have traditionally played the important role in compression for contemporary communication application. In this paper it demonstrated that a multistage implementation of sampling rate conversion often provides for a more efficient realization, especially when filter specifications are very tight (e.g., a narrow pass band and narrow transition band) and there are a audio-band of 4kHz bandwidth and compression by decimator to isolate the frequency component 80Hz. The LPF used by the decimator are acquire by two different approaches: first is the window method and other is frequency sampling method, Multistages implementations are used to further reduce the computational load. This approach drastically reduces the filter order and also reduces computational cost. Here it have reduce the overall computational complexity at single stage is 50 times and for second stages is near about 9 times reduce by the decimator factor is 50.

**Keywords:** DSP, Decimator, FIR, Multirate, MATLAB.

### I. Introduction

The widespread use of digital representation of signals for transmission and storage has created challenges in the area of digital signal processing. Changing in the sampling rate of audio signal is common task in the signal processing field. In many practical application of digital signal processing, one is faced with the problem of changing the sampling rate of a signal, either expending it or reducing it by some quantity. for example, in telecommunication system that transmit and receive different type of signal (eg., teletype, speech, video, etc.), There is a demand to process the different signals at different rates commensurate with the corresponding bandwidth of the signals. The process of changing a signal from a given rate to a different rate is called sampling rate conversion. In turn, systems that hire multiple sampling rates in the processing of digital signals are called multirate digital signal processing (DSP) systems. The noble identity states the equality of filtering when a filter is exchange with the down-sample or up sample operator which is shown in Fig.1 shows the two cases of the noble identity. Now assume it have a low pass filter whose transfer function is given by  $H(z)$ . A polyphase representation of the transfer function is:

$$H(z) = \sum E_i(z^M) \quad (1)$$

Every one of the  $E_i(z^M)$  terms in equation (1) is known as “one phase” of the actual transfer function  $H(z)$ . It is simple to see that the phases can be implemented by using the noble identity. Thus, the low pass filtering can be done at a lower sampling rate. This conducts to decrease computational cost.

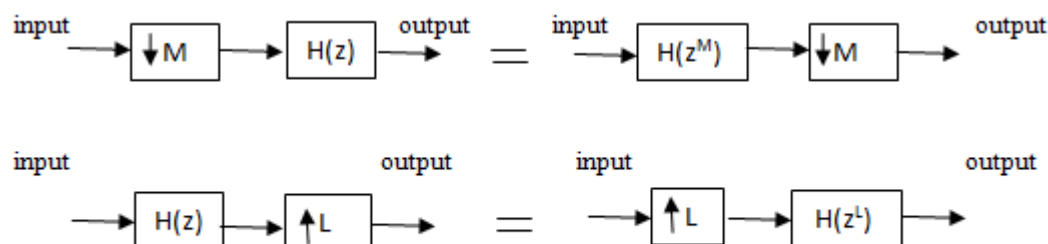

Fig 1. (Noble Identity)

Although In numerous practical applications the sampling rate is changed by a fractional number, say,  $M / L$ . In such expressions, both decimation and interpolation are required to achieve the sampling rate conversion. In order to maintain the quality of the source audio, the narrowband frequency is done by the first decimator the source signal by the factor  $M$  followed by low pass filtering and interpolation by a factor  $L$  [1]. In the implementation of Narrow band Low pass Filter(LPF) by the compression of the audio band of 4KHz bandwidth by the multistage implementation of decimator of size  $M$ , followed by a multistage implementation

of an interpolator of size L, where L=M. For narrow pass band and narrow transition band, so in this condition a low pass, linear phase FIR filter may be more efficiently implemented in multistage decimator-interpolator configuration. So the output of multistage implementation by decimator by narrowband LPF will produce compressed signal, so by the window method or frequency sampling method to measure the length of the filter, for single stage or multistage after that find the computational complexity.

### II. Decimators

Basically low pass filters (LPF) are used for decimation and for interpolation. When decimating, low pass filters are used to decrease the bandwidth of a signal initial to decreasing the sampling rate. This is done to reduce aliasing due to the reduction in the sampling rate. When decimating, the bandwidth of a signal is decrease to an suitable value so that minimal aliasing occurs when decreasing the sampling rate



Fig.2 (Down Sampler)

Down sampler is primary sampling rate alteration appliance used to reduce the sampling rate by an integer factor. An down-sampler with a down-sampling factor M, where M is a positive integer, develops an output series y[n] with a sampling rate that is (1/M)-th of that of the input sequence x[n]. The down sampler is shown in Fig2 [2]. Decomposition of a signal into M components carrying a different frequency bands, If the original signal is sampled at the sampling frequency f<sub>s</sub> (with a frequency band of width f<sub>s</sub>/2, or half the sampling frequency), each element then carry a frequency band of width 2f<sub>s</sub>/M only, and can be represented using the sampling rate f<sub>s</sub>/M. This authorize for efficient parallel signal processing with processors operating at lower sampling rates. The technique is also applied to data compression in implementation of narrowband low pass filter (LPF), for example in communication processing, where the high frequency (audio-band) band components are represented with different narrowband. Multistage implementation of decimation by factor M shown in fig3

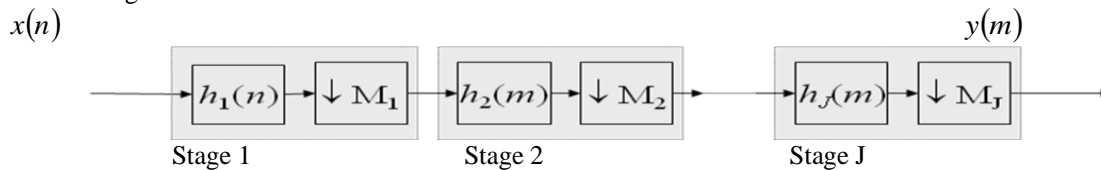

Fig.3 (Multistage implementation by factor M)

### III. Multistage Implementation Of Sampling Rate Conversion

In practical application of sampling-rate conversion it often encounter decimation factor and interpolation factor that are much larger then unity. It consider method for achieve sampling rate change for either M>>1 and/or L>>1 in multiple stages. First let us consider interpolation by a factor L>>1and let us suppose that L can be factorizing into a product of positive integers as. The filter in every one of the interpolators eliminates the images introduce by the up sampling process in the corresponding interpolator.

$$L = \prod_{i=1}^J L_i$$

In a similar way, decimation by a factor M, Where M may be factored into a product of positive integer as

$$M = \prod_{i=1}^J M_i$$

Can be implemented as a cascade of J stages of filtering and decimation as shown in fig.3. So the sampling rate at the output of the ith stage is

$$F_i = F_{i-1} / M_i \quad i=1,2,\dots,J$$

Where the input rate for the sequence {x(n)} is F<sub>0</sub>=F<sub>x</sub>. To ensour that no aliasing arise in the final decimation process. It can design each filter stage to avoid alising within the frequency bands of interest. To elaborate ,let us define the desired passband and transition band in the overall decimator is

$$\text{Passband: } 0 \leq F \leq F_{pc}$$

$$\text{Transition band: } F_{pc} \leq F \leq F_{sc} \tag{2}$$

Where F<sub>sc</sub> ≤ F<sub>x</sub>/2M. Then,aliasing in the band 0 ≤ F ≤ F<sub>sc</sub> is avoided by selecting yhe frequency band of each filter stage as follows:

$$\begin{aligned}
 &\text{Passband: } 0 \leq F \leq F_{pc} \\
 &\text{Transition band: } F_{pc} \leq F \leq F_i - F_{sc} \\
 &\text{Stopband: } F_i - F_{sc} \leq F \leq (F_i - 1/2)
 \end{aligned} \tag{3}$$

For example, in the first filter stage it have  $F_i = F_x / M_1$ , where the  $F_x$  is the input frequency which is compressed by decimator at different stages.

$$\begin{aligned}
 &\text{Passband: } 0 \leq F \leq F_{pc} \\
 &\text{Transition band : } F_{pc} \leq F \leq F_i - F_{pc} \\
 &\text{Stopband : } F_i - F_{pc} \leq F \leq F_0/2
 \end{aligned} \tag{4}$$

After decimation by  $M_1$ , there is aliasing from the signal element that fall in the filter transition band, but the aliasing occurs at frequency above  $F_{sc}$ . Thus there is no aliasing in the frequency band  $0 \leq F \leq F_{sc}$ . By designing the filter in the following stages to content the specification given in equation (3), it ensure that no aliasing arise in the primary frequency band  $0 \leq F \leq F_{sc}$ .

$$N = \frac{-10 \log \delta_1 \delta_2 - 13}{14.6 \Delta f} \tag{5}$$

It is a particularly simple formula for approximation the order of filter  $N$ , and length of the filter is calculated by the  $D = (N+1)$ , attributed to Kaiser, is shown in equation (5) where  $\Delta f$  is the normalized (by the sampling rate) width of the transition region [i.e.,  $\Delta f = (F_{sc} - F_{pc}) / F_s$ ] [3].

In this paper the sampling rate change from 8KHz to 160Hz, which required  $M = F_x / 2F_{fc} = 50$  here it want to lowpass filter  $F_{pc} = 75$  HZ and  $F_{sc} = 80$  HZ,  $F_{pc}$  and  $F_{sc}$  are the passband and the stopband frequency, respectively where  $\delta_1$  and  $\delta_2$  are the passband and the stopband ripple. Choose the value of  $\delta_1 = 10^{-2}$  and  $\delta_2 = 10^{-4}$ , when it found the order of filter is  $N = 5151$ . In practice, it is difficult to implement a filter with such a high order. An another way is to do the low pass filtering (LPF) in multiple stages, and each stage need a much lower filter order. And it also find the value of filter length is  $N+1 = 5152$ . For reducing the order of the filter by the different stages in the multistage implementation by decimation factor  $M$ , which is shown in fig.3.

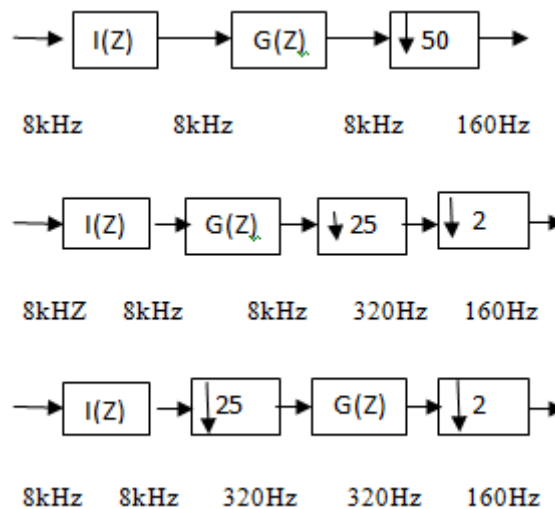

Fig.3 (Two stage filtering)

It know that in Fig .3 is the decimation factor  $M_1 \times M_2 = M = 50$ , it find the decimation value  $M = 50$ , by compression of signal from 8 KHz to 160 Hz, their it comress the audio band signal to the narrowband signal with the help of two stage filtering, in the two stage Factorize the transfer function  $H(z) = G(z^{M_1}) I(z)$ , and then by the noble identity, the system in Fig. 2 can be implemented by two stage filtering and decimations. It require  $G(z^{M_1})$  to have the similar low pass specifications as  $H(z)$ , and use  $I(z)$  to eliminate the images of  $G(z^{M_1})$ , then the two-stage filtering in fig.3.

#### IV. Implementations and Simulation

In first stage filtering there are it downsampled by the factor  $M = 50$  by the relation of  $M = F_x / 2F_s$ , where  $F_x$  is equal to the audio band sampled rate, and  $F_s$  is equal to the generate narrow band sampled rate. It know the value of passband ripple  $\delta_1 = 10^{-2}$  and stopband ripple  $\delta_2 = 10^{-4}$  as per the LPF it also find the value of filter length  $D$  with the help of kaiser window, that is equal to 5152. finally find out the computational complexity, which is equal to the 824160 MPS (multiplication per second), by the equation.(7). For first stage implementations. For an FIR  $H(z)$  of

$$R_{M,FIR} = N \times F_T \tag{6}$$

For an FIR  $H(z)$  of length  $N$  followed by a down-sampler.

$$R_{M,FIR-DEC} = N \times F_T / M \tag{7}[4,]$$

When it note that in Fig. 3, for two stage implementations the decimation factors  $M_1 \times M_2 = M = 50$ . If it demand  $G(z^{M_1})$  to have the similar low pass specifications as  $H(z)$ , and use  $I(z)$  to eliminate the images of  $G(z^{M_1})$ , then the two-stage filtering in Fig. 3 have the similar frequency response as  $H(z)$ . Fig. 4 drawing the principle of this two stage IFIR approach. For more feature on the underling multirate signal processing theory. The advantage of using this IFIR implementation is that the transition bandwidth  $\Delta\omega$  in equation (5) can be mainly relaxed on both filters  $I(z)$  and  $G(z)$ , therefore much lower filter orders are required to implement them. And find the computational complexity by the equation (7), for two stages. The next section describes design details of the IFIR approach.

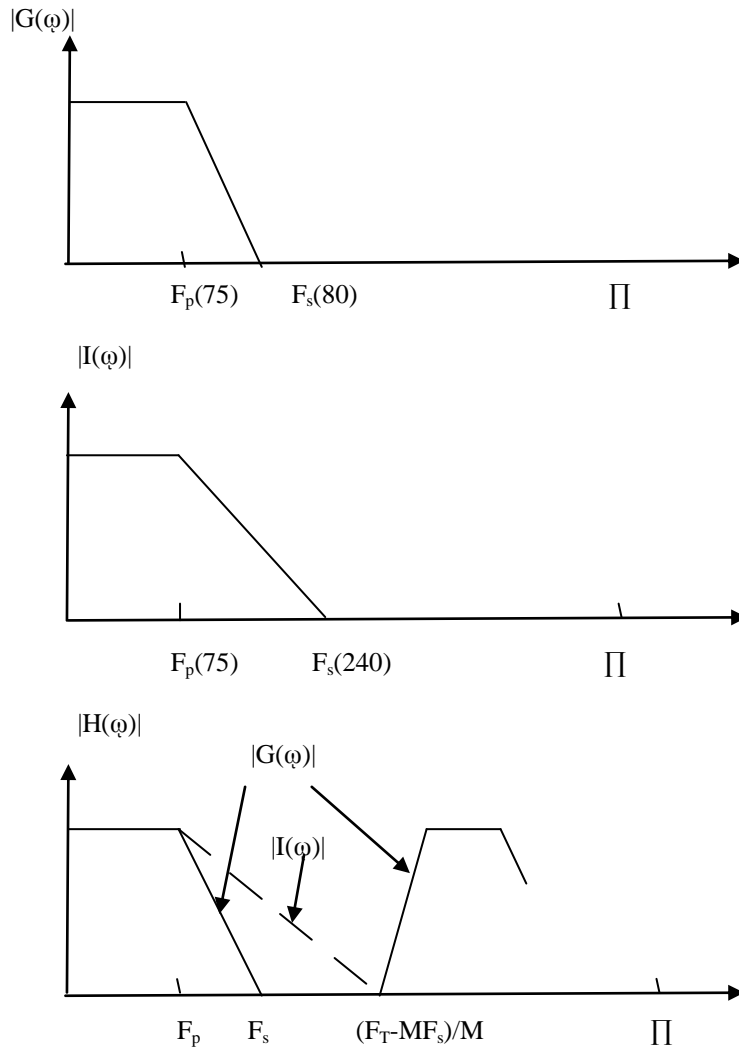

Fig.(4) Frequency Response Two Stage Filtering

Simulation result of  $G(z^M)$

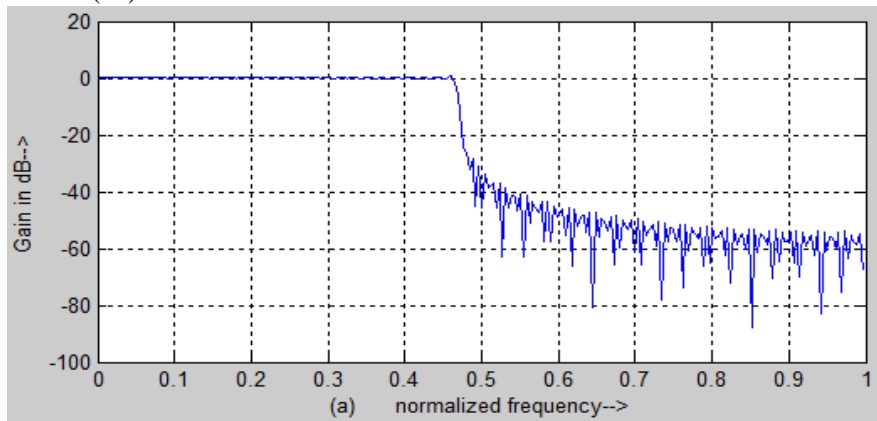

Fig.(5)  $G(z^M)$  filter response

Simulation result of  $I(z)$

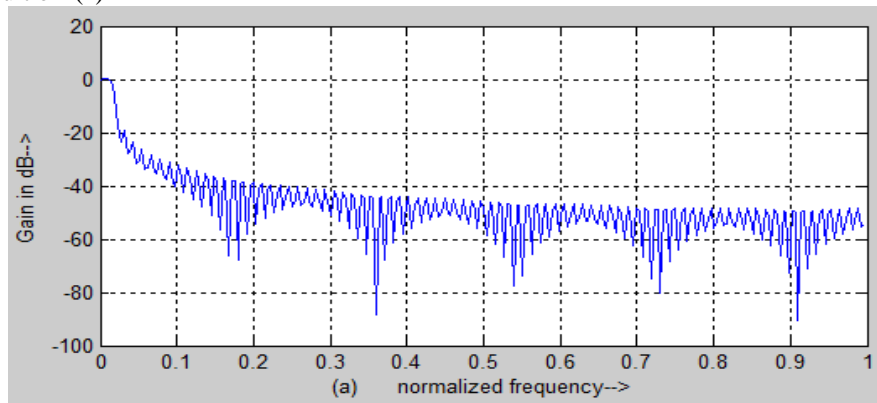

Fig.(6)  $I(z)$  filter response

Simulation result of both filter is shown in fig-5-6.[5]

## V. Design

The decimation factor  $M=25 \times 2$  then  $M_1=25$ ,  $M_2=2$ , a two stage decimator is implemented with  $H(z) = G(z^{25})I(z)$ . Filters  $G(z)$  and  $I(z)$  are designed in Matlab with the parameters given in section 3,4. Then first stage it have specified  $G=320$  Hz and

Passband:  $0 \leq F \leq 75$

Transition band :  $75 < F \leq 240$

$\Delta f=165/8000$

Ripple:  $\delta_{11}=\delta_1/2$ ,  $\delta_{21}=\delta_2$

Note that it have reduce the passband ripple  $\delta_1$  by a factor of 2 so the total passband ripple in the cascade of two filter does not exceed  $\delta_1$ . On the other hand, the stop band ripple is maintained at  $\delta_2$  in both stage.  $\Delta f$  is find by  $(F_s - F_p)/F_T$ , where  $F_s$  is syopband  $F_p$  is passband frequency By kaiser formula yields an estimate of length of filter  $D_1=167$ , and order of filter is 166, computational complexity of this stage is 53120(MPS), by equation (7). For the second stage, it have  $I=G/2=320/2=160$  and spacification

Passband:  $0 \leq F \leq 75$

Transition band:  $75 < F \leq 80$

$\Delta f=5/320$

Ripple :  $\delta_{11}=\delta_1/2$ ,  $\delta_{21}=\delta_2$

Hence the estimate of the length  $D_2$  of the second filter is =220 and order of filter is 219 by kaiser farmula. The computational complexity of  $I$  is 35040(MPS).

Therefore, the total length of the two FIR filter is approximately  $D_1+ D_2=387$ . Thus represent the reduction in the length of filter by a factor of more then 13. Thus the reduction in the filter length result from

increasing the factor  $\Delta f$ , which is appears in the denominator in equation (5). By decimating in multiple stages, it are able to increase the width of the transiton region through a reduction in sampling rate.[7]

**TABLE 1**

Filter order of window and computaionl complexity

Filter	Kaiser Window	Computational Complexity(MPS)
$G(z)$	219	35040
$I(z)$	166	53120

**TABLE 2** Filter oredr of window and computaionl complexity(MPS) and result how much complexity reduce.

No of Stages	Filter Length	(MPS)	Result
Without dceimator	5152	41208000	-----
First stage (decimator)	5152	824160	50 time reduce (MPS)
Second stage (decimator)	387	88160	9.3time reduce again(MPS)

### VI. Experimental Result

To evaluate the performance of the multistage implimentation of narrow band LPF and mesure the filter order by the MATLAB program of kaiser window , and aslo find the length and the computational complexity for multistages ,which is shown in Table 1,2. Table 1 show that computational complexity for both the filter  $G(z)=35040$ ,  $I(z)=53120$  , computational complexity is find in term of number of multiplications per second, computational efficiency is improved significantly.Resion for using multistage are

- 1.Multistage system requires reduced computation
- 2.storage space required is less
- 3.Finite word length effects are less

Table 2 show the computation for different stage first this show the without decimator, second show the first stage with decimator and third show the second stage with decimator,where the  $M=50$  downsampled for conversion a 4kHz audio band into 80Hz narrowband frequency siganl with the help of multistage technic.

Result in Table 2 show that how much number of computation is reduce in term of multiplication per second . When it take first stage in decimator then the computation is reduce 50 time shown in Table, when consider second stages then the no MPS (multiplications per seconds) is 9.3 times reduce.

### VII. Conclusion

In this paper, genrate the narrowband by the audioband with the help of multistage implimentation . Here it also find the how much computation is reduce in MPS , which is shown in "Tabel 2" for different stages. The order of filter is also reduce , when computation load is less so the delay is also less ,so speed is increased due to different stages . so that multistage decimator are best for performing downsampling and provide less computation solution and also cost effective solution for DSP based wireless communication applications. Here it have reduce the overall computational complexity at single stage is 50 times and 824160 multiplication per second (MPS) for second stages is near about 9 times and 88160 multiplication per second (MPS) reduce by the decimator factor is 50.

### References

- [1] Wen Jin, Michael S. Scordilis, Alexander Iliev “Comparison and Implementation of a 16-bit Fixed-point Audio Resampler”, IEEE Conference Publications, Vol.2, DOI: 10.1109/ACSSC.2004.1399472 PP: 1798 – 1800,2004
- [2] Rajesh Mehra, Swapna Devi, “ Optimized Design of Decimator for Alias Removal in Multirate DSP Applications”, ISSN: 1790-2769, ISBN: 978-960-474-189-2, PP:100-103 ,2010
- [3] John G.Proakis,Dimitris G. Manolakis , “Digital Signal Processing “,4th Edition,PP PEARSON Prentice Hall An imprint of Pearson Education. PP: 750 – 822, 2007.
- [4] S. K. Mitra, “Digital Signal Processing” A Computer-Based Approach, McGraw-Hill, NY, PP: 655 – 738,1998.
- [5] Mathworks, “ Users Guide Filter Design Toolbox-4”, March-2007.
- [6] S salivahanan.A Vallavaraj.C Gnanapriya, “Digital Signal Processing ”,Twenintieth reprint 2006,Tata McGraw -Hall, New Delhi,PP:555-565,1993.
- [7] Shahriar Emami “New Methods for Computing Interpolation and Decimation Using Polyphase Decomposition”, IEEE TRANSACTIONS ON EDUCATION, VOL. 42, NO.4, PP: 311 – 314, NOVEMBER 1999.
- [8] R Mehra, S Devi, “FPGA Based Design of High Performance Decimator using DALUT Algorithm”, ACEEE International Journal on Signal and Image Processing, Vol.1,No.2,PP:9-13,2010
- [9] R Mehra, R Arora, “FPGA-Based Design of High-Speed CIC Decimator for Wireless Applications” , (IJACSA) International Journal of Advanced Computer Science and Applications, Vol. 2, No. 5,PP:59-62,2011 [10] R Mehra, L Singh, “FPGA based Speed Efficient Decimator using Distributed Arithmetic Algorithm” International Journal of Computer Applications , International Journal of Computer Applications, Volume 80 – No 11,PP-37-40, 2013
- [11] Jovanovic Dolecek, G.; Mitra, S.K., “Efficient comb-rotated sinc (RS) decimator with sharpened magnitude response” IEEE Conference Publications,Vol.2,PP:117-120,2004
- [12] S Chu, CS Burrus,” Multirate filter designs using comb filters” IEEE Transactions on, ISSN :0098-4094,Volume:31 PP:913-924, 1984

### Authors Profile



**Prashant Kumar** received the Bachelors of Technology degree in Electronics and Communication Engineering from Uttar Pradesh Technical University, Lucknow, India in 2013. He is pursuing Masters of Engineering degree in Electronics and Communication Engineering from National Institute of Technical Teachers’ Training & Research, Panjab Univrsity, Chandigarh, India



**Rajesh Mehra** received the Bachelors of Technology degree in Electronics and Communication Engineering from National Institute of Technology, Jalandhar, India in 1994, and the Masters of Engineering degree in Electronics and Communication Engineering from National Institute of Technical Teachers’ Training & Research, Panjab Univrsity, Chandigarh, India in 2008. He is pursuing Doctor of Philosophy degree in Electronics and Communication Engineering from National Institute of Technical Teachers’ Training & Research, Panjab Univrsity, Chandigarh, India.

He is an Associate Professor with the Department of Electronics & Communication Engineering, National Institute of Technical Teachers’ Training & Research, Ministry of Human Resource Development, Chandigarh U.T. India. His current research and teaching interests are in Signal Processing, Very Large Scale Integration Design. He has more than 150 Journal and Conference publications. Mr. Mehra is life member of ISTE